



LIMITED LIFETIME WARRANTY

Compass Manufacturing International warrants to the original consumer purchaser that the faucet be free from defects in material and workmanship for as long as the original consumer purchaser owns the home in which the faucet was first installed.

In the event that Freendo Faucets are used in a Commercial Application, this warranty is limited for a period of 5 years, unless otherwise specifically stated in the catalog and/or price book.

Compass Manufacturing International will replace, free of charge, during the applicable warranty period, any part or finish that proves defective in material and/or workmanship under normal installation, use and service. This warranty shall not apply to goods which have been subject to accidents, negligence or improper installation. Compass Manufacturing International will not be liable for other damages or losses, including, but not limited to: labor charges and/or damages incurred in installation, repair or replacement as well as any other kind of loss or damage. Proof of purchase from the original consumer purchaser must be made available for all warranty claims.

Compass Manufacturing International recommends using a professional plumber for all installation and repair. Compass Manufacturing International will, at its discretion, provide new or equivalent replacement parts for any product that proves to be defective under normal usage and service. Replacement parts may be obtained by emailing the address below, calling the number below or by writing to:

Compass Manufacturing International

Freendo Product Service

6702 Enterprise Drive

Louisville, KY 40214

800.626.3525

warranty@cmiproduct.com

Revised 12/24/19

warranty@cmiproduct.com

© Compass Manufacturing International

800.626.3525



Model No. : 192-6407 Polished Chrome
192-6408 Brushed Nickel *Spotless* PVD™
192-6409 Oil-Rubbed Bronze
192-7153 Matte Black
192-7152 Matte Gold



Cardania Roman Tub Faucet
3 Hole Installation, 6"-10" Center-Set



Helpful Information

Helpful Tools

Tools:

Gather the necessary tools as shown below to complete the installation of this faucet. Some may not be needed depending on the model of faucet you are installing.



Plumber's Putty
and/or Silicone

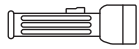

Flashlight



Basin Wrench



Safety Glasses



Screwdriver



Pliers



Channel Locks



Adjustable Wrench

Maintenance

Your new faucet is designed for years of trouble-free performance. Keep it looking new by cleaning it periodically with a soft, damp cloth. Avoid abrasive cleaners, steel wool and harsh chemicals as these will dull the finish and void your warranty.

Safety Tips

- If you use soldering for the installation of the faucet, the seats, cartridges and washers will have to be removed before using flame. Otherwise, the warranty will be void on these parts.
- Protect your eyes with safety glasses when cutting or soldering water supply line.
- Cover your drain to avoid losing parts.

Important Points

Prior to beginning installation, turn off the cold and hot water lines and turn on the old faucet to release built-up pressure. When installing your new faucet, turn the connector nuts finger tight, then use a wrench to anchor the fitting and a second wrench to tighten the nut one additional turn. Connections that are too tight can compromise the integrity of the system. Wrap all threaded connections with teflon tape. Always wrap in a clockwise direction.

5

Troubleshooting

If the instructions were followed carefully and the faucet does not work properly, try these corrective steps.

Problem	Cause	Action
Leaks underneath the handle (#1).	Lock nut (#17) has come loose.	Turn off the water supplies. Remove the handle (#1) and tighten the lock nut (#17). Reinstall the handle (#1).
The water will not shut off completely.	Dirty or damaged cartridge (#25 or #36).	Turn off the water supplies. Remove the handle base (#5), lock nut (#17) and cartridge (#25 or #36). Check the ceramic disk for dirt and damage. If the cartridge (#25 or #36) is damaged, replace the cartridge (#25 or #36). If the cartridge (#25 or #36) is dirty, soak it in warm white vinegar for 4 hours. Every 30 minutes, while the cartridge (#25 or #36) is completely submerged, turn the stem on and off 10 times. Reinstall the cartridge (#25 or #36), lock nut (#17) and handle base (#5).
The aerator (#14) leaks or has an inconsistent water flow pattern.	Aerator (#14) is dirty or misaligned.	Remove the aerator (#14), using the aerator wrench (#35) provided and rinse the aerator with warm water. Replace or reinstall the aerator (#14), using the aerator wrench (#35) provided.

Have a question? DON'T GO BACK TO THE STORE, WE CAN HELP, just call 1-800-626-3525 ,8 a.m. to 5 p.m. EST Monday-Friday, or send an email to Help@cmiproduct.com.

4

Configuration

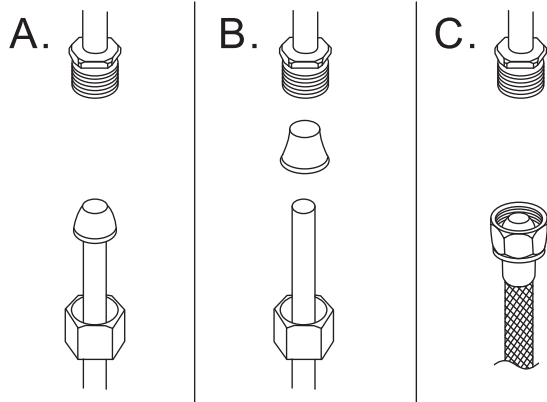

Warning:
The supply valves and supply lines are not included.

Connect to water supply lines with either:

- (A) 3/8" O.D. Copper tubing (ball nose risers with the coupling nuts or;
- (B) 3/8" Copper tubing (no ball) with supplied tube head interior connector or;
- (C) IPS faucet connectors (1/2")

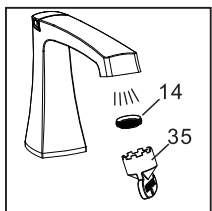

Important:

Remove the aerator (#14), using the aerator wrench (#35) provided. Turn on both the cold and hot water, let it run for one minute. This will help clear the lines of any debris that might clog the system. Reinstall the aerator (#14), using the aerator wrench (#35) provided.

Test for leaks.

1

Parts Diagram

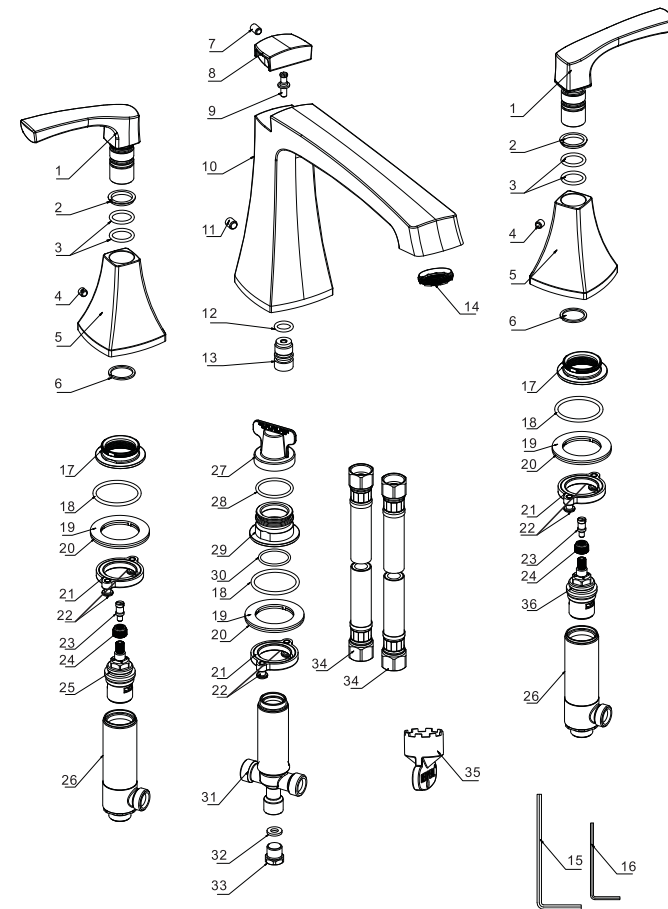

No.	Part Name
1	Handle
2	O-ring
3	O-ring
4	Set Screw
5	Handle Base
6	Handle Connector
7	Screw
8	Knob
9	Knob Connector
10	Spout
11	Set Screw
12	O-ring
13	Stopper
14	Aerator
15	Allen Wrench
16	Allen Wrench
17	Lock Nut
18	O-ring
19	Washer
20	Clamp
21	Lock Nut
22	Screws
23	Set Screw
24	Handle Adapter
25	Cartridge (Hot)
26	Brass Valve Body
27	Cap
28	O-ring
29	Spout Lock Nut
30	O-ring
31	Brass Waterway
32	Washer
33	Stopper
34	Connect Hoses
35	Aerator Wrench
36	Cartridge (Cold)

2

Faucet Installation

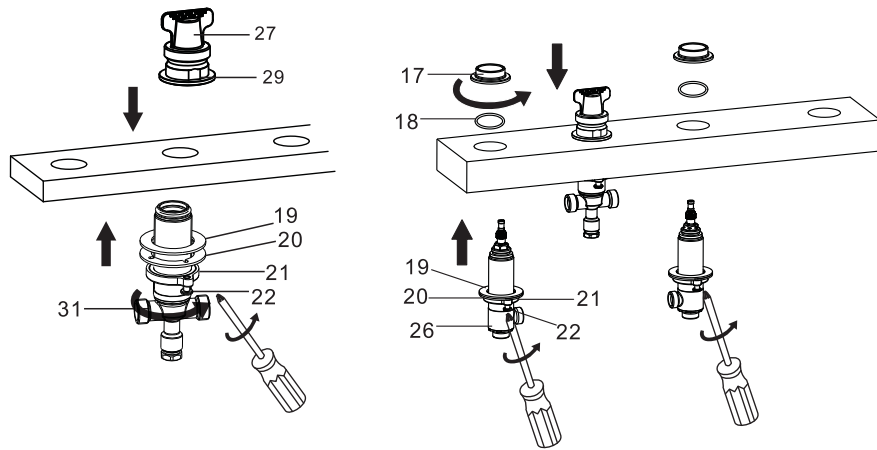

1. Shut off the water supplies and drain the lines. Clean and dry the mounting surface thoroughly.
2. Remove the spout lock nut (#29) and cap (#27) from the brass waterway (#31). Ensure the lock nut (#21) is far enough down on the brass waterway (#31) to fit your mounting surface. From underneath the mounting surface, insert the brass waterway (#31) into the second hole from the left. From above, reinstall the spout lock nut (#29). Tighten the lock nut (#21) hand tight. Using a screw driver, tighten the screws (#22). Do NOT overtighten.
3. Remove the lock nut (#17) from the brass valve body (#26). Ensure the lock nut (#21) is far enough down on the brass valve body (#26) to fit your mounting surface. From underneath the mounting surface, insert the brass valve body (#26) into the far left hole. From above, reinstall the lock nut (#17). Tighten the lock nut (#21) hand tight. Using a screw driver, tighten the screws (#22). Do NOT overtighten. Repeat this step for the cold water side.

3

Faucet Installation

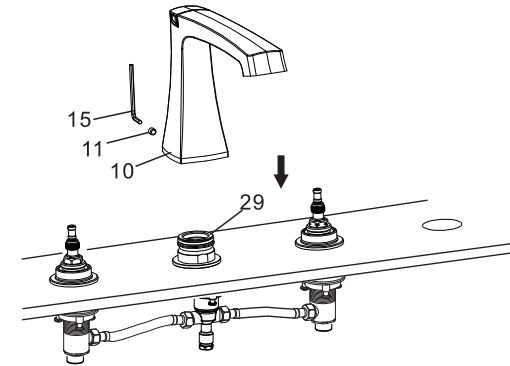

4. Slide the spout (#10) onto the spout lock nut (#29) and lock into place with the set screw (#11), using the Allen wrench (#15) provided.

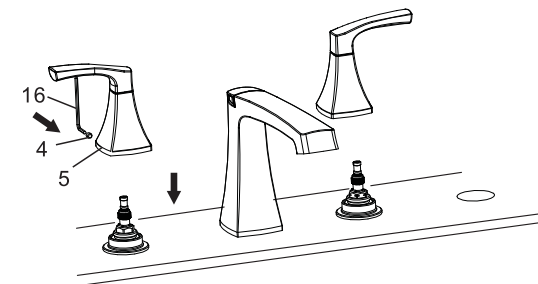

5. Slide the handle base (#5) onto the lock nut (#17) and lock into place with the set screw (#4), using the Allen wrench (#16) provided.