



## LIMITED LIFETIME WARRANTY

Compass Manufacturing International warrants to the original consumer purchaser that the faucet be free from defects in material and workmanship for as long as the original consumer purchaser owns the home in which the faucet was first installed.

In the event that Freendo faucets are used in a Commercial Application, this warranty is limited for a period of 5 years, unless otherwise specifically stated in the catalog and/or price book.

Compass Manufacturing International will replace, free of charge, during the applicable warranty period, any part or finish that proves defective in material and/or workmanship under normal installation, use and service. This warranty shall not apply to goods which have been subject to accidents, negligence or improper installation. Compass Manufacturing International will not be liable for other damages or losses, including, but not limited to: labor charges and/or damages incurred in installation, repair or replacement as well as any other kind of loss or damage. Proof of purchase from the original consumer purchaser must be made available for all warranty claims.

Compass Manufacturing International recommends using a professional plumber for all installation and repair. Compass Manufacturing International will, at its discretion, provide replacement parts for installation by consumer for any parts that prove defective under normal usage and service with new or equivalent parts. Replacement parts may be obtained by emailing the address below, calling the number below or by writing to:

### Compass Manufacturing International

Freendo Product Service

6702 Enterprise Drive

Louisville, KY 40214

800.626.3525

[warranty@cmiproduct.com](mailto:warranty@cmiproduct.com)

Revised 7/8/16

[warranty@cmiproduct.com](mailto:warranty@cmiproduct.com)

© Compass Manufacturing International

800.626.3525



Model No. : 212-5910

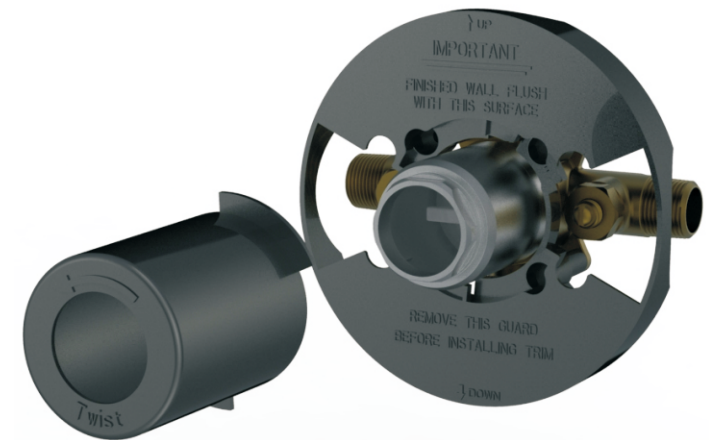

**CONTRACTOR VALVE PACK  
SWEAT AND MALE NPT**



## Helpful Information

### Helpful Tools

#### Tools:

Gather the necessary tools as shown below to complete the installation of this faucet. Some may not be needed depending on the model of faucet you are installing.



Plumber's Putty

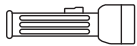

Flashlight



Basin Wrench



Safety Glasses



Screwdriver



Pliers



Channel Locks



Adjustable Wrench

# 5

## Parts List

19	Screw
18	End Cap
17	Washer
16	Teflon tape
15	Integral Stop Locknut
14	O-ring
13	Adjuster
12	O-ring
11	Spring
10	Stopper
9	Sealing Washer
8	Valve body
7	O-ring
6	Pipeline Testing Stopper
5	O-ring
4	Locknut
3	Protective kit
2	Protective sleeve
1	Screw
<b>No.</b>	<b>Part Name</b>

# 4

## Parts Diagram

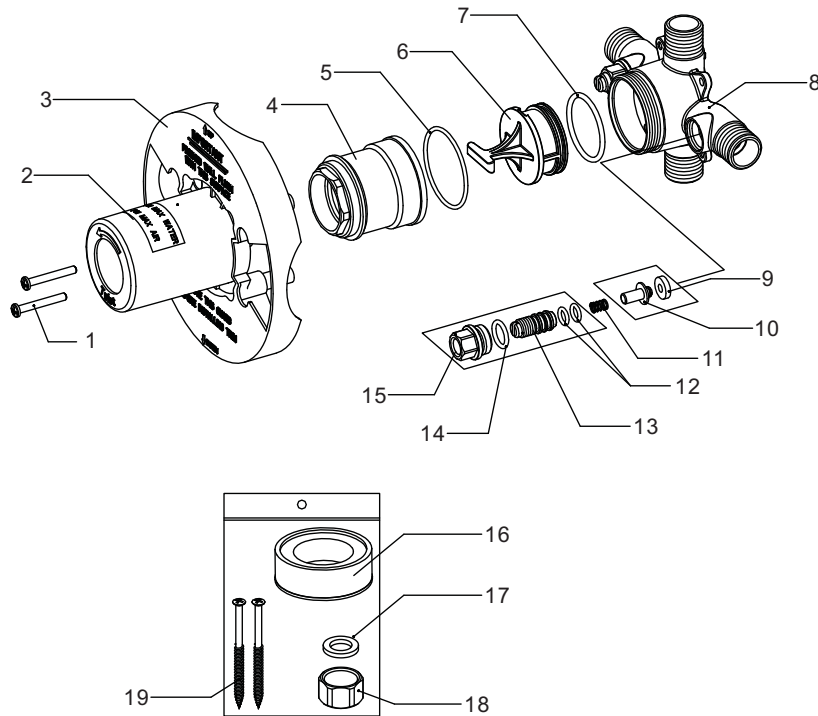

※Cartridge is included with trim kit.

# 1

## Faucet Installation

1.

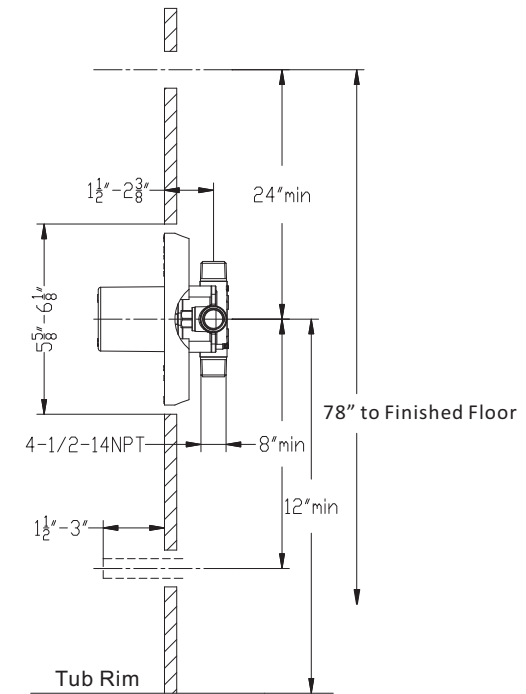

1. Make sure the valve is properly oriented. The word "UP" on the valve body should be pointed towards the shower riser and the word "DOWN" should be pointed towards the tub spout outlet. Insert valve assembly with plaster guard into cut hole in wall. The flat surface marked "IMPORTANT" on the plaster guard should be FLUSH with the finished wall surface.

CAUTIONS: 1/2" Copper or larger required for drop from valve to tub spout to prevent back pressure that will cause leakage from shower head when discharging water through tub spout.

## 2

### Faucet Installation

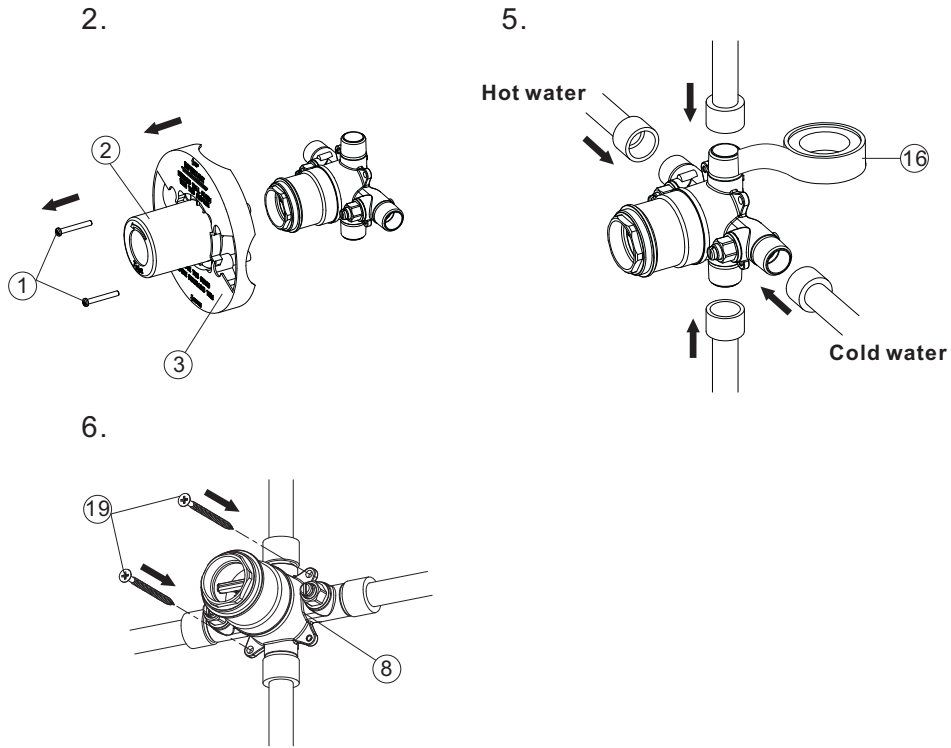

2. Remove the screws (1), protective sleeve (2), protective kit (3) as shown.
3. If sweating in, please remove stop valves so they are not damaged.
4. Replace stop valves after brass body has cooled properly.
5. Connect pipes with faucet by teflon tape (16) as shown, pay attention to the connection of hot and cold water supply pipe.  
CAUTIONS: If the shower head or spout is not needed, use the washer to plug the valve hole of "DOWN" or "UP".
6. Tighten the screw (19) to fix the valve body (8) into the wall.

## 3

### Configuration

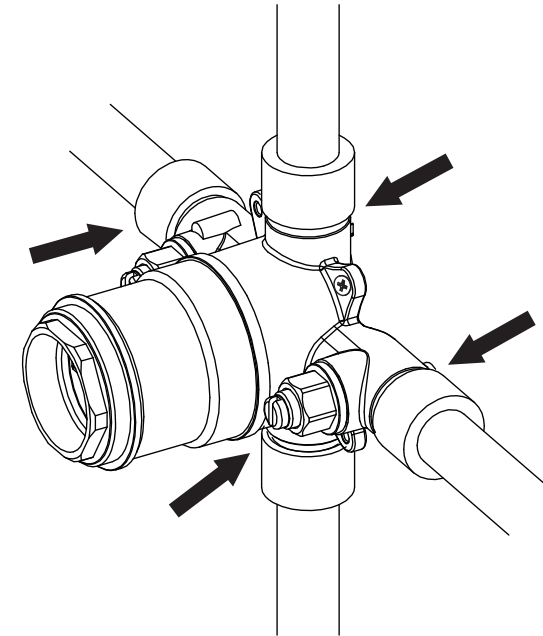

Turn on water and check for leaks. If there are leaks, please reinstall.