

Contractor Valve with Crimp PEX Connection Facing Up Type B - F1807

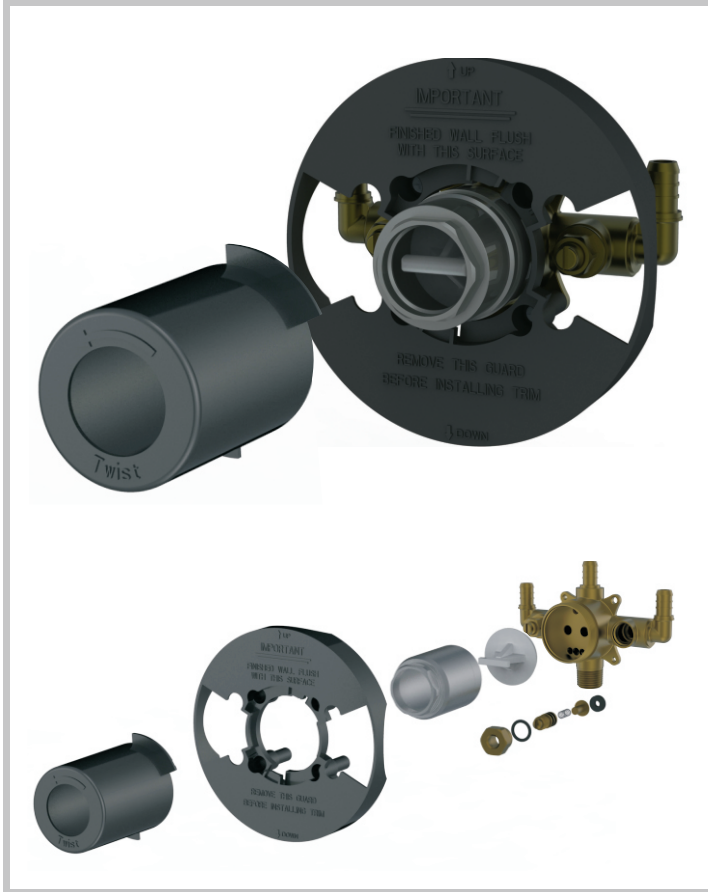

Model No. : 212-5911

- * Brass Valve Body Only
- * Requires Anti-Scald Pressure Balanced Ceramic Cartridge (Type F) - Trim Pack with Cartridge Sold Separately
- * Integral Stops
- * 1/2" PEX crimp connections and 1/2" Universal outlets (Sweat) with Male NPT threads
- * Includes brass plug for Shower only
- * Includes pressure test kit

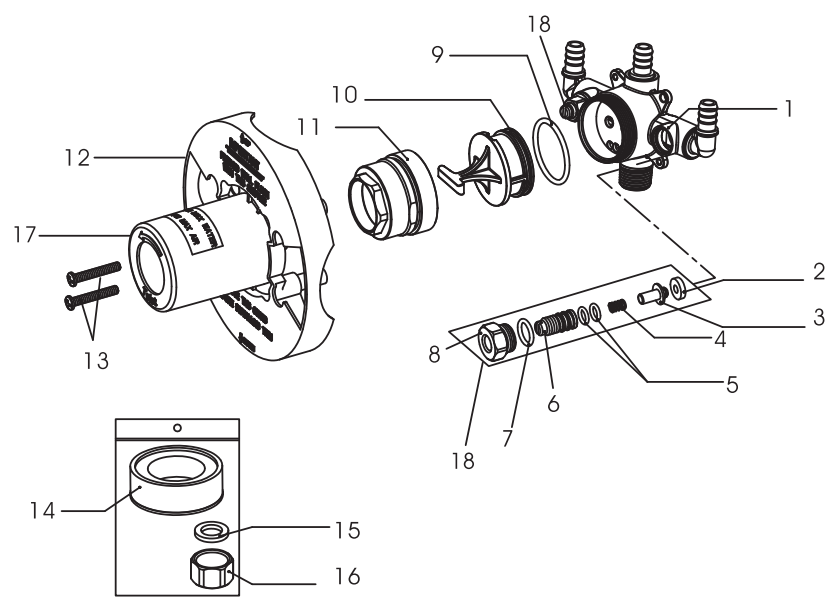

NO.	Part Name
1	Valve Body
2	Sealing Washer
3	Stopper
4	Spring
5	O-rings
6	Adjuster
7	O-ring
8	Adjuster Seat
9	O-ring
10	Test Plug
11	Cartridge Lock Nut
12	Plaster Guard
13	Screws
14	Teflon Tape
15	Washer
16	End Cap
17	Protective Sleeve
18	Integral Stops

Product Compliance:
 • ASME A112.18.1 / CSA B125.1
 • ANSI A117.1 (ADA)
 • ASSE 1016